



REGIONAL APPLICATIONS

THE MICHELIN® X® MULTI™ D TIRE

The next generation regional drive tire offering first-class tire mileage and excellent scrub resistance with no compromises to traction.

Line Haul	Regional	Urban*	On/Off Road
<input checked="" type="checkbox"/>	<input checked="" type="checkbox"/>	<input type="checkbox"/>	<input type="checkbox"/>

Recommended Acceptable



**MAXIMIZED
TREAD LIFE**

**EXCELLENT
TRACTION⁽¹⁾**

**CASING
DURABILITY**



* Urban would include fleets that operate in an Urban construction environment that operate off road a maximum of 10%.

1. Next-generation traction and mileage. Guaranteed. See your Michelin Representative, Authorized Michelin Dealer, or visit www.MichelinTruck.com for details.

www.michelintruck.com



MICHELIN

THE MICHELIN® X® MULTI™ D TIRE

MAXIMIZED TREAD LIFE

Co-Extruded Compounding Scrub Resistant Rubber

- Ensures high mileage in the most demanding applications

Go The Distance

- 65% more mileage⁽¹⁾ than the MICHELIN® XDE® M/S tire.

Long Even Wear

- Incorporates Matrix™ siping and a bridged open shoulder.

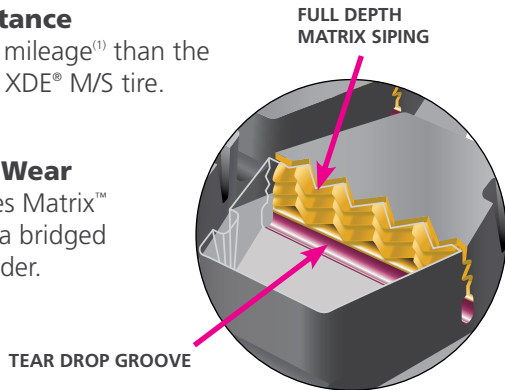

CASING DURABILITY

Cooler Running Rubber

- Minimizes heat build up leading to increased casing life.



TW6 OzoneShield™ –

- Double treatment of the sidewall for increased protection and lasting professional look

Full Width Protector Ply

- Protects the tire from nail penetrations and road hazards from shoulder to shoulder.



EXCELLENT TRACTION

More Grip, Less Slip- Zero to On The Road 80% faster than a leading competitor.⁽²⁾

Full Depth Matrix™ Siping

- The sipe goes all the way to a tear drop groove, meaning no loss of the biting grip as the tire wears.

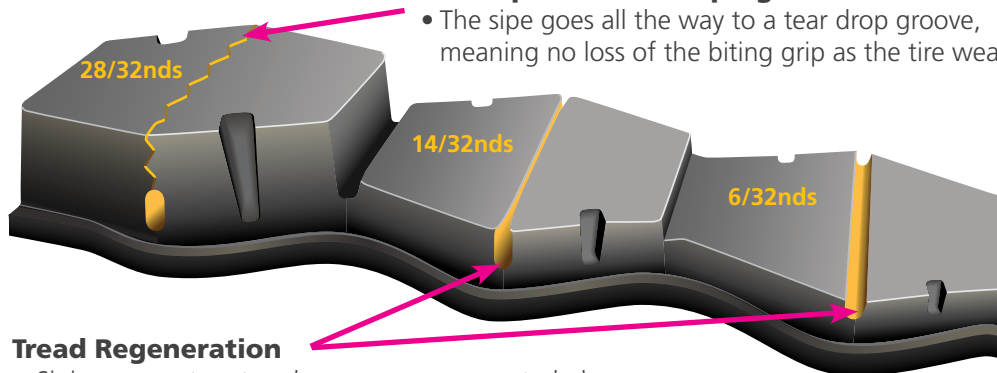

Tread Regeneration

- Siping opens to a tread groove once worn to help with additional water evacuation and traction

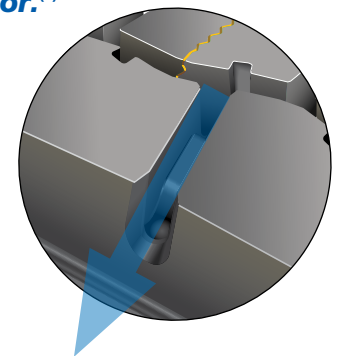

Pass Thru Open Shoulder

- Allows quick evacuation of material from beneath the tread surface area.

Line Haul	Regional	Urban ⁽³⁾	On/Off Road
Recommended	Acceptable		

Size	Load Range	Catalog Number	Tread Depth	Max. Speed (*)	Loaded Radius	Overall Diameter		Overall Width (‡)		Approved Wheels (Measuring wheel listed first.)	Min. Dual Spacing (‡)		Revs Per Mile	Max. Load and Pressure Single				Max. Load and Pressure Dual				
			32nds	mph	in.	mm	in.	mm	in.		mm	in.		mm	lbs.	psi	kg.	kPa	lbs.	psi	kg.	kPa
10R22.5	G	74441	18	75	18.9	479	40.3	1023	9.7	247	7.50, 6.75	11.4	290	514	5675	115	2575	790	5355	115	2430	790
11R22.5 ⁽⁴⁾	G	33502	28	75	19.5	495	41.8	1062	11.3	288	8.25, 7.50	12.5	318	496	6175	105	2800	720	5840	105	2650	720
11R22.5 ⁽⁴⁾	H	80276	28	75	19.6	498	41.9	1064	11.3	288	8.25, 7.50	12.5	318	494	6610	120	3000	830	6005	120	2725	830
255/70R22.5 ^(4,5)	H	76760	24	75	17.4	442	37.0	940	10.3	261	8.25, 7.50	11.3	287	558	5510	120	2500	830	5070	120	2300	830
275/80R22.5 ⁽⁴⁾	G	76710	28	75	19.0	483	40.5	1029	11.0	280	8.25, 7.50	12.2	311	510	6175	110	2800	760	5675	110	2575	760
11R24.5 ⁽⁴⁾	H	27287	28	75	20.5	521	43.8	1112	11.2	284	8.25, 7.50	12.5	318	472	7160	120	3250	830	6610	120	3000	830

Note: Wheel listed first is the measuring wheel.

(1) Results based on 2 small scale internal field tests using customer fleet vehicles using MICHELIN® X® MULTI™ D tires versus MICHELIN® XDE® M/S tires in 11R22.5 size. Actual results may vary.

(2) In a standardized snow test, the 11R22.5 MICHELIN® X® MULTI™ D tire travelled 80% further from start versus the 11R22.5 Bridgestone® M726 ELA tire. Actual results may vary.

(3) Urban would include fleets that operate in an Urban construction environment that operate off road a maximum of 10%.

(4) Next-generation traction and mileage. Guaranteed. See your Michelin Representative, Authorized Michelin Dealer, or visit www.MichelinTruck.com for details.

(5) Available 2nd Quarter 2018.

(*) Exceeding the lawful speed limit is neither recommended nor endorsed.

(‡) Overall width will change 0.1 inch (2.5 mm) for each 1/4 inch change in wheel width. Minimum dual spacing should be adjusted accordingly.

MICHELIN® tires and tubes are subject to a continuous development program. Michelin North America, Inc. reserves the right to change product specifications at any time without notice or obligations. Please consult wheel manufacturer's load and inflation limits. Never exceed wheel manufacturer's limits without permission of component manufacturer.

TO FIND OUT MORE
michelintruck.com

FIND US ON FACEBOOK
michelintruck.com

CONTACT US BY EMAIL
michelintruck.com/contact-us/

CONTACT US BY TELEPHONE
1-888-622-2306

Michelin North America Inc., One Parkway South, Greenville, SC 29615, 1-888-622-2306

Copyright © 2018 Michelin North America, Inc. The Michelin Man is a registered trademark owned by Michelin North America, Inc. All rights reserved.

An Equal Opportunity Employer MWL10005 POD (REVISED 04/18)